

CORALIGHT® 6000

The new sustainable
polyurethane board



CORALIGHT® 6000

***The new sustainable polyurethane boards
produced by upcycling***



CORALIGHT® 600 is the new high-density (600 kg/m³) polyurethane board made by DUNA Corradini through the upcycling of high quality production by-products. Consisting of 87% recycled raw material, CORALIGHT® 600 high-density boards combine sustainability, technical performance and aesthetic requirements.

CORALIGHT® 600 adds excellent physical-mechanical performance in terms of resistance, screw retention, low water absorption and workability to the typical insulating properties of polyurethane, making it suitable for a variety of applications, from construction to furnishings, from structural reinforcement to refrigeration systems. The new CORALIGHT® 600 polyurethane boards are the latest DUNA innovation, part of the larger "ZERO WASTE" project.

Inaugurated in 2015 and in line with the 2030 Agenda Green Goals, this DUNA project aims to recover and enhance polyurethane scrap through the UpCycling process.

Quality production scraps are thus transformed into a valuable resource, capable of generating new products with superior properties and performance compared to the starting material, otherwise sent to disposal.

For a full circular economy, the DUNA Group has developed a new industrial upcycling plant, dedicated to the production of CORALIGHT® 600, inaugurated in July 2021 at its headquarters in Soliera (MO, Italy)

Advantages

from Upcycling 

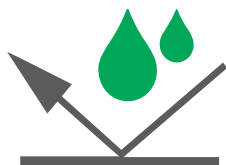

Water resistant

Low water absorption and lower swelling compared to other wood-based and recycled materials

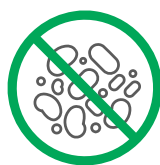

Resistant to bacteria and chemicals

Unaffected by bacterial agents and moulds. Resistant to solvents and chemicals



Valuable aesthetics

High full-body homogeneity and perfect surface finish for aesthetically pleasing applications



100% polyurethane

Homogeneity and purity of the material. No pores, grains or discontinuities. Easy to dispose of



High screw retention

Excellent mechanical and screw resistance features, superior to wood and other recycled materials



Thermal insulation

Ability to reduce heat loss and eliminate thermal bridges



Euroclass E

Fire reaction classification for combustible insulation materials



Easy workability

Easy to mill, cut, drill, coat, bond and paint



Finishing versatility

Compatible with most adhesives, primers and other finishing substances

Sizes

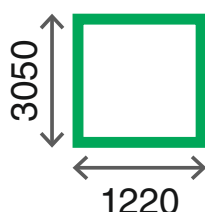

Available in large size: 1220x3050 mm boards



Boards of customisable thickness, from 10 to 100 mm



Customised sub-sizes or thicknesses on request

Applications of CORALIGHT® 600

Thanks to the technical and mechanical properties typical of high-density polyurethane (600 kg/m³), the new CORALIGHT® 600 boards are suitable for a variety of applications

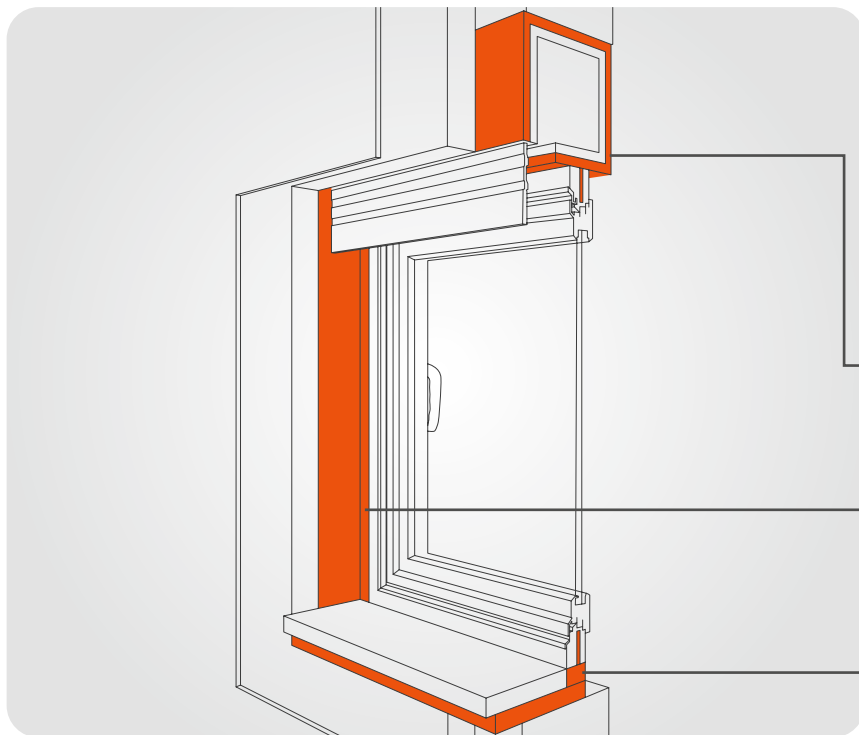

Windows and frames

Window frames and counter frames, exterior door panels, roller shutter boxes, window sills and thresholds

- Box
- Insulated window reveal
- Insulated window sill

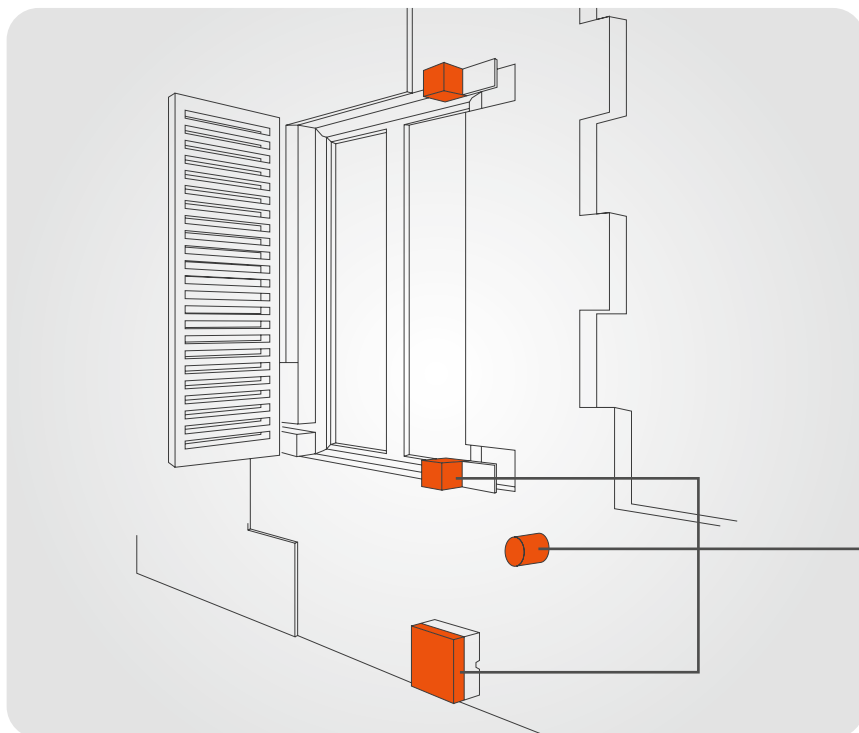

Thermal coats and building insulation

- Coat anchoring elements

600
kg/m³

With high performance

Panels for refrigerated systems

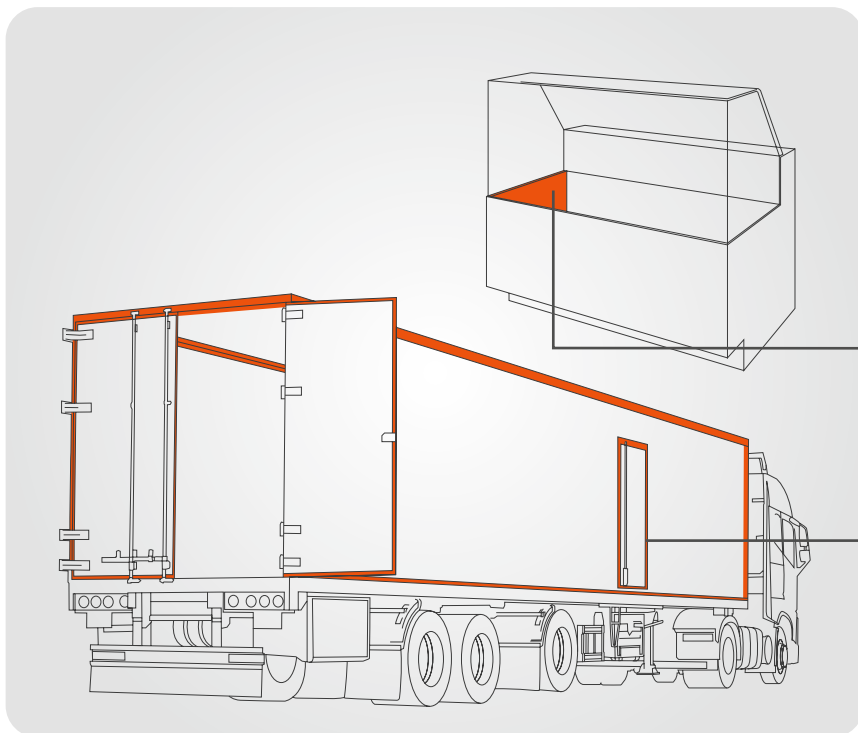

Insulating panels for counters and refrigeration systems

Reinforcement structures for refrigerated vehicles

Outdoor and technical furniture

Furniture and accessories for yachts and motorhomes

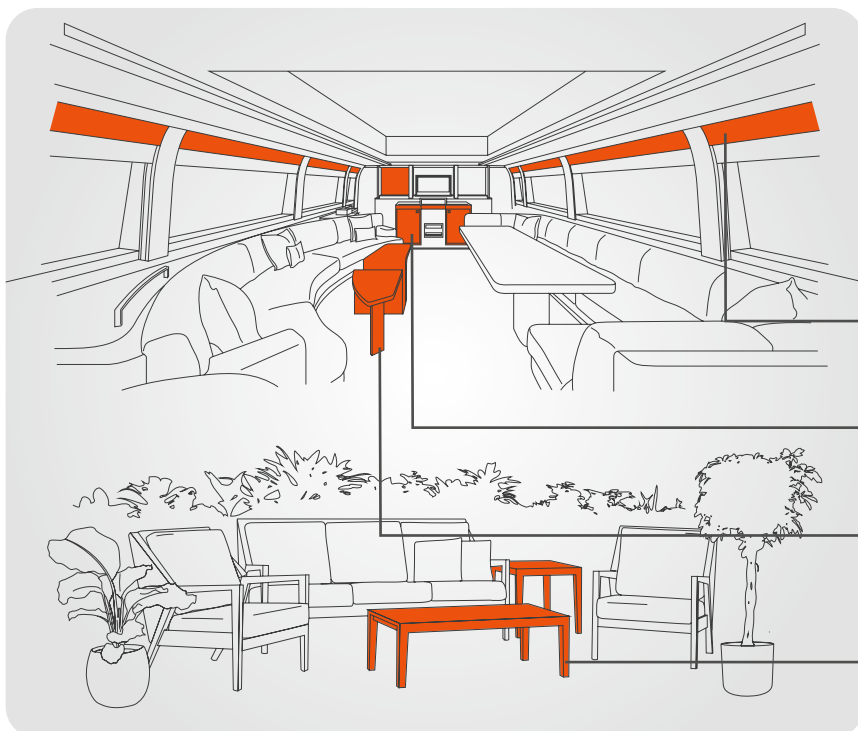

Mouldings, profiles and door wings

Reinforcement and insulation panels in refrigerated systems

Tables, shelves and furniture

Outdoor tables and furniture

High density polyurethane board

from Upcycling



Main properties	Method	Test conditions		U.o.M.	Typical value
Nominal density	EN 1602/ASTM D1622			kg/m ³	600
Thermal conductivity	EN 12667/ASTM C518/ASTM C177	-10°C	Initial	mW/mK	75
		0°C	Initial	mW/mK	78
		10°C	Initial	mW/mK	80
		20°C	Initial	mW/mK	83
Colour					Beige
Closed cells	EN ISO 4590/ASTM D6226			%	45
Operating temperature				°C	-30 / 100
Mechanical properties	Method	Test conditions		U.o.M.	Typical value
Resistance to compression	EN 826/ASTM D1621	23°C	Parallel	MPa	13 / 17
Compression modulus				MPa	230 / 310
Resistance to compression			Perpendicular	MPa	16 / 19
Compression modulus				MPa	320 / 410
Flexural strength	EN 12089/ASTM C203		Parallel	MPa	11 / 16
Bending elastic modulus				MPa	460 / 530
Tensile strength	EN 1607/ASTM D1623		Perpendicular	MPa	10
Tensile modulus				MPa	180
Shear strength	EN 12090/ASTM C273	MPa		1.50	
Cutting modulus		MPa		19	
Maximum flexural strain				%	0.034 / 0.040
Dimensional stability	EN 1604/ASTM D2126	70°C, 48 h; relative ambient humidity	Length	%	-0.1
			Width	%	-0.1
			Thickness	%	-0.1
		-25°C, 48 h	Length	%	-0.05 / 0.05
			Width	%	-0.05 / 0.05
			Thickness	%	-0.05 / 0.05
Fire properties	Method	Test conditions		U.o.M.	Typical value
Fire reaction	DIN 4102			Class	B2
	EN 13501/EN 11925		Blocks, slabs	Euroclass	E
Other properties	Method	Test conditions		U.o.M.	Typical value
Water absorption	EN 317			kg/m ²	< 0.2
Water absorption in percentage	EN 317			%	1.8
Water absorption	EN 1609			kg/m ²	0.18
Hygroscopic absorption properties	EN ISO 12571	23°C, 80% relative humidity		%	2.6
Water vapour resistance coefficient	EN 12086/ASTM E96	23°C, 50% relative humidity			13
Surface hardness	EN ISO 868/ASTM D2240		D	Shore D	55 / 60
Swelling thickness	EN 317			%	0.25
Screw resistance	EN 320			kgf	153

Note: the terms parallel and perpendicular refer to the direction of the thickness of the slab or block



UNI EN ISO 9001:2015
 UNI EN ISO 14001:2015
 UNI ISO 45001:2018



CERTIQUALITY
 IS MEMBER OF
 CISQ FEDERATION

Recommendations for bonding, painting and fixing

CORALIGHT® 600 high-density polyurethane has excellent adhesion properties and is compatible with most commercially available coating materials. Before proceeding with full coating, it is in any case recommended to carry out a preliminary test on a sample of material. In the case of outdoor applications or exposure to atmospheric agents, a UV-protection coating is recommended.

The CORALIGHT® 600 material is resistant to solvents and chemicals and has an open cell structure that is homogeneous in size and composition. This facilitates the preparatory stages of painting and makes it possible to realise a variety of fine finishing effects, including high-gloss mirror painting.

Due to the fact that it consists exclusively of polyurethane, CORALIGHT® 600 is preferably suitable for bonding with 1- or 2-component PU adhesive systems, considering the compatibility with other systems. Due to the porous characteristics of the material, the use of high-fluidity adhesives is not recommended.

The use of conventional fasteners such as screws, nails and staples requires consideration of the specific properties of the material with regard to the mechanical stresses exerted:

Warning

The values given represent typical properties obtained through laboratory tests under controlled boundary conditions and in no way constitute sales specifications. They are based on the current knowledge and experience of DUNA-Corradini if the products are stored, handled and applied in accordance with the recommendations in the Safety Data Sheet (SDS) or the Product Safe Use Information Sheet. It is also the customer's responsibility to ensure that handling, storage and disposal are carried out in accordance with applicable laws and to ensure that application methods, personal protective equipment (PPE) and workstations are suitable and compliant with applicable regulations.

overloads or excessive compression can cause spontaneous fractures or surface cracks. It is always advisable to carry out preliminary tests on a small area to check the mechanical strength of the material.

For assembly with screws or screwed hardware, it is recommended to pre-drill with a drill bit whose diameter is similar to the core of the screw. It is recommended to maintain sufficient distance from the edge (approx. 7-10 x screw diameter) and between the different fasteners (approx. 5-10 x screw diameter*). If possible, flat rather than countersunk screws are preferred to minimise the risk of breakage.

Recommended adhesives

DUNAPOL® AD 1564	2K THIXO
DUNAPOL® AD 1670	2K
DUNAPOL® AD 4020	1K
DUNAPOL® AD 3153	1K

*The data shown are the result of tests carried out by the DUNA Corradini R&D Laboratory, performed on CORALIGHT® 600 board, 25 mm thick, and are to be considered purely indicative. These data have no legal value and do not represent official values on which to base structural and design calculations.

For information on PPE, transport, storage and disposal of product residues, it is essential to refer to the SDS or the Product Safe Use Information Sheet. We recommend storing in the original packaging, in a covered, dry place, sheltered from direct sunlight and away from heat sources. DUNA-Corradini disclaims all liability for direct and indirect damage of any kind to persons or property including loss of profits. This edition cancels and replaces all previous editions. DUNA-Corradini reserves the right to change the data contained in the information sheet at any time, at its own discretion.

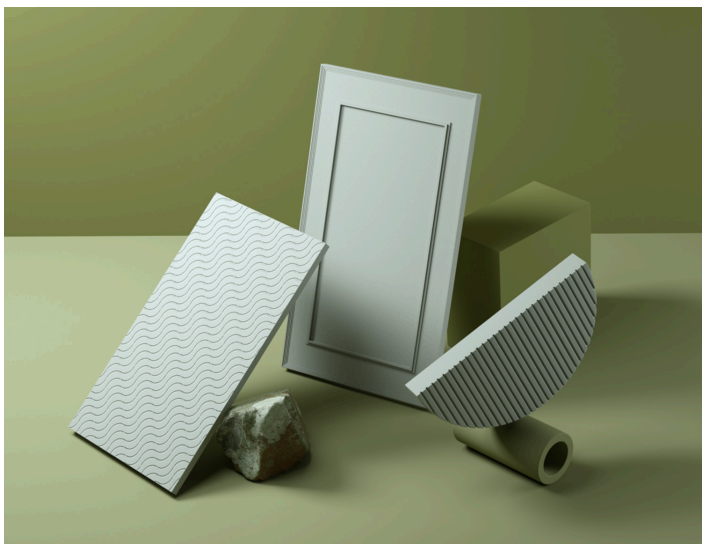

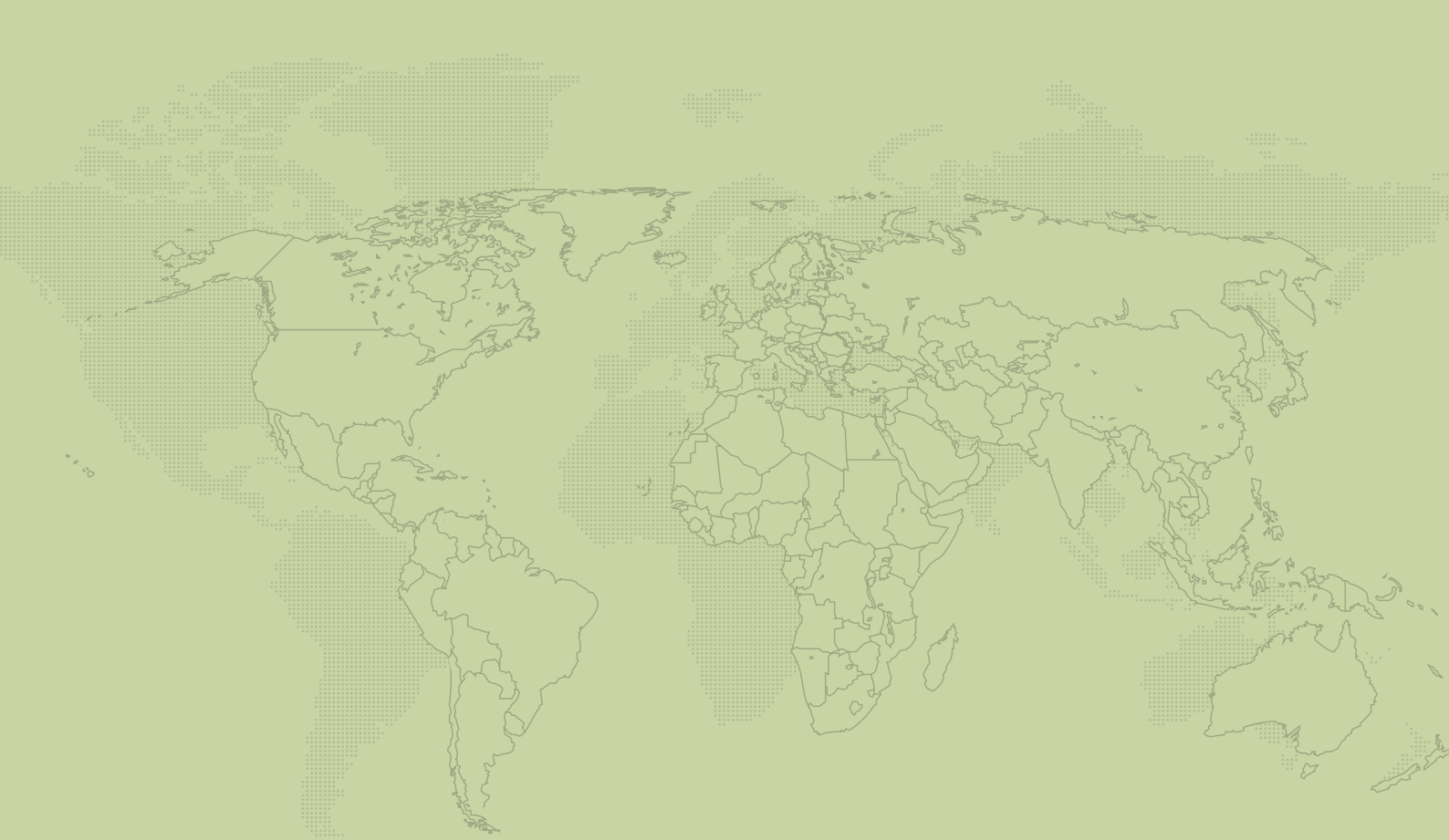

DUNA-Corradini
FOAMS & CHEMICALS

DUNA-CORRADINI SpA

Via Modena Carpi, 388
41019 Soliera,
MODENA, Italy
Tel.: (+39) 059 893911
Fax: (+39) 059 565403

info@dunagroup.com
www.dunagroup.com



DUNA-USA
FOAMS & CHEMICALS

DUNA-USA Inc.

4210 FM 1405 Baytown, Texas 77523 - U.S.A.
Tel.: (+1) 281 383 3862
TOLL FREE: 866 383 DUNA
5900 West 6th street
Ludington, Michigan 49431 - U.S.A.
Tel.: (+1) 281 383 0115

info-dunausa@dunagroup.com
www.dunagroup.com/usa



DUNA-Emirates
FOAMS & CHEMICALS

DUNA-EMIRATES LLC FZC

P.O. Box 50024
Fujairah, U.A.E.
Tel.: (+971) 09 228 2409
Fax: (+971) 09 228 2399

info-dunaemirates@dunagroup.com
www.dunagroup.com/emirates

